

Design of a Modified Braking System Mechanism for Two Wheeler Vehicles to Increase Safety of the Rider

Ashish Kumar Rohilla, Anuj Kumar Sehgal

Department of Mechanical and Automobile Engineering, Sharda University, Greater NOIDA

Abstract— *The present disclosure relates generally to a braking system for a two-wheeler vehicle that enables linkage between the front and rear brakes to help attain a safe braking ratio under all circumstances. In an aspect, the present disclosure provides a mechanical linkage between front and the rear brakes of a two-wheeler vehicle, wherein the linkage can be installed without removing any component of existing braking systems/architectures, and wherein the linkage can enable automatic application of brake on a second brake when brake is applied on a first brake. For instance, when front brake (for the front wheel, for instance) is applied, automatic and ideal proportional brake can be automatically applied to the rear brake (for the rear wheel, for instance), and vice versa.*

Keywords— *Automatic application, braking system, linkage, safe braking ratio.*

I. INTRODUCTION

The present disclosure relates generally to a braking system, particularly to a braking system for a two-wheeler vehicle that enables linkage between the front and rear brakes to help attain a safe braking ratio under all circumstances.

In the existing motorcycle, the braking mechanisms for both the front and rear wheels are respectively controlled by an individual braking lever and a brake paddle which are pivotally mounted at right hand side of the handlebar for the front brake and foot operated paddle for the rear brake respectively. Normally, it is hard to depress both braking levers simultaneously and synchronously. If the front wheel is stopped and the back wheel is still running, the tail of the motorcycle will swing aside and in most serve situation, the motorcycle may fall down resulted from this unbalanced situation. On the other hand, as the riding speed increases, the braking force required to stop the wheels are also increased proportionally. If the front brake lever and rear braking paddle can be simultaneously depressed, the braking forces will be doubled and the bicycle and/or motorcycle can be stopped in a balanced

manner. As a matter of fact, when both the front and rear wheels are stopped simultaneously, the motorcycle can be kept in balance without skidding, pitching, or yawing.

In existing braking systems of motorcycles therefore, the front wheel is stopped by applying the brake lever on the right hand of the handle, and the rear wheel is stopped by pressing the brake paddle by the right foot. Both the brakes are independent and there is no inter-connection between the two brakes, wherein, in normal conditions, our mind gets time to get coordination between hand and foot to get a safe braking i.e. to apply both the brakes in a specific ratio. In adverse conditions however, when the reaction time is very less, or balancing or controlling has to be done along with the braking, it becomes difficult to attain a safe braking ratio, and sometimes either only the hand or only the foot brake is pressed.

There is therefore a need in the art for a braking system that provides a linkage between the front and the rear brakes such that by pressing either of the front/rear brake, the other brake will automatically be applied in ideal proportion.

II. OBJECTS OF THE MECHANISM

It is an object of the present disclosure to compensate for human errors in applying brakes.

It is another object of the present disclosure to provide a braking system that enables a linkage between the front and the rear brakes such that by pressing either of the front/rear brake, the other brake will automatically be applied in ideal proportion.

It is another object of the present disclosure to provide a braking system that can be installed in motorcycles without removing any component of existing brakes.

It is another object of the present disclosure to provide a braking system that uses simple mechanical components such as gears and/or wires to achieve the linkage between the two brakes.

It is another object of the present disclosure to provide a braking system that requires no external energy input to achieve the linkage between the two brakes.

III. DIAGRAMS

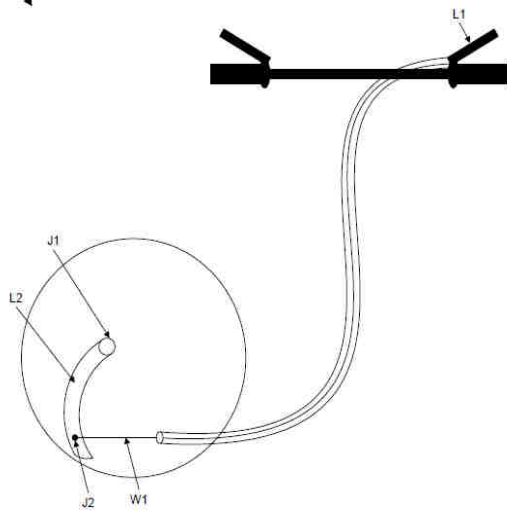

FIG. 1 (Prior Art)

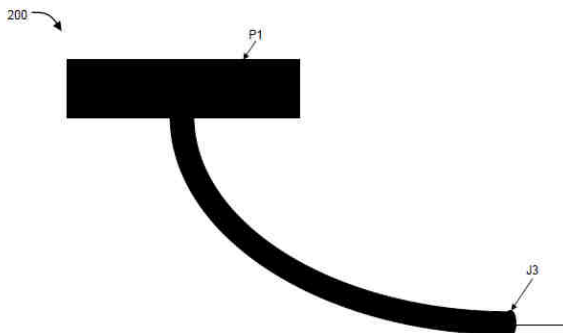

FIG. 2 (Prior Art)

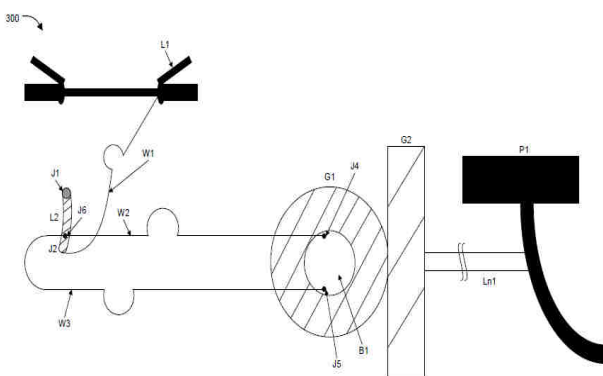

FIG. 3

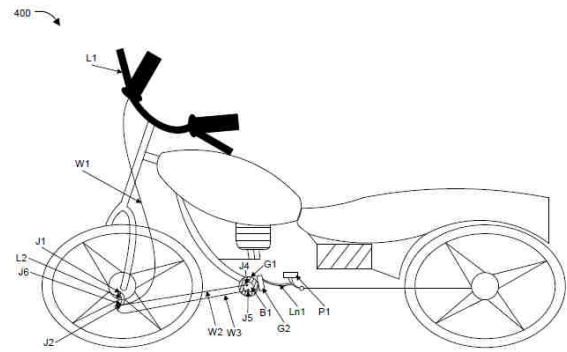

FIG. 4

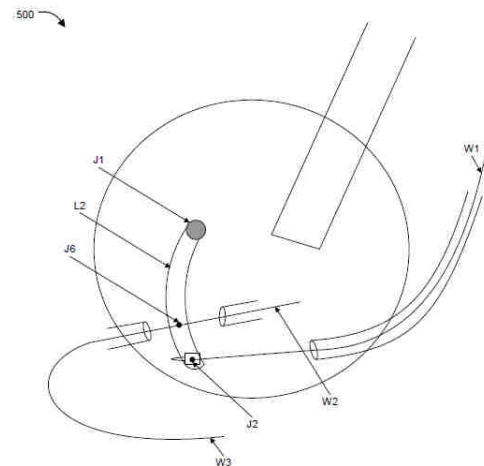

FIG. 5

FIG. 1 illustrates an exemplary representation of components of an existing front brake assembly in accordance with an embodiment of the present disclosure. FIG. 2 illustrates an exemplary representation of components of an exemplary rear brake assembly in accordance with an embodiment of the present disclosure. FIG. 3 illustrates an exemplary assembly of the proposed brake linkage construction in accordance with an embodiment of the present disclosure.

FIG. 4 illustrates another exemplary assembly of the proposed brake linkage construction in accordance with an embodiment of the present disclosure.

FIG. 5 illustrates an exemplary front brake assembly of the proposed brake linkage construction in accordance with an embodiment of the present disclosure.

IV. DETAILED DESCRIPTION

FIG. 1 illustrates an exemplary representation of components of an existing front brake assembly in accordance with an embodiment of the present disclosure. As shown, the existing front brake assembly 100 can include and/or be coupled with a front brake lever L₁, which can be pressed by hand to activate the brake for the front wheel. The assembly 100 can further include a first wire W₁ that can connect the front brake lever L₁ with second lever L₂, wherein the second lever L₂ can be configured to rotate anti-clockwise depending on the wire

W_2 or W_1 that is in tension. The assembly 100 can further include a first joint J_2 that joins the first wire W_1 with the second lever L_2 , and a second joint J_1 that is the joint of second lever L_2 with the brakes.

FIG. 2 illustrates an exemplary representation of components of an exemplary rear brake assembly 200 in accordance with an embodiment of the present disclosure. The assembly 200 can include a rear brake paddle P_1 , which is to be pressed by foot. The assembly 200 can further include a third joint J_3 that represents the joint of the rear brake paddle P_1 with the rear brake.

With reference to FIG s. 3-5, in an aspect of the present invention, when front brake lever L_1 is pressed, tension in created in a first wire W_1 that operatively couples the front brake lever L_1 with a second lever L_2 . The second lever L_2 is coupled with the first wire W_1 at a second joint J_2 and is hinged at first joint J_1 . Tension in the first wire W_1 causes anti-clockwise rotation of the second lever L_2 , causing tension in wire W_3 as W_3 is joined to L_2 at J_6 , which tension in W_3 causes first gear G_1 to rotate clockwise, thereby inducing a vertical downward motion of second gear G_2 as both the gears are meshed. In an aspect, downward movement of the second gear G_2 causes downward motion of brake paddle P_1 (causing brake to be applied to the rear wheel) that has to be pressed by foot as the second gear G_2 is joined with the paddle P_1 through a link $Ln1$.

In another aspect of the present disclosure, when the rear brake paddle P_1 is pressed, the second gear G_2 moves vertically downwards as both the paddle P_1 and the second gear G_2 are connected through the link $Ln1$. Vertical downward movement of the second gear G_2 causes the first gear G_1 to rotate in clockwise direction, which rotation induces tension in wire W_2 , causing second lever L_2 to rotate in anti-clockwise direction, thereby activating front brake .

FIG. 3 illustrates an exemplary assembly 300 of the proposed brake linkage construction in accordance with an embodiment of the present disclosure. The linkage construction 300 can include a lever link $Ln1$ connecting the rear brake paddle P_1 with the second gear G_2 . Gears G_1 and G_2 form a rack and pinion arrangement and are meshed with each other. Bush B_1 is attached to the first gear G_1 on which the wire W_2 and W_3 are to be wrapped and joined. Joint J_4 represents the fixed joint of the wire W_2 and the bush B_1 , whereas joint J_5 represents the fixed joint of wire W_3 and the bush B_1 . Joint J_6 , on the other hand, is the fixed joint of second wire W_2 with second lever L_2 , and at the same point also joins the wire W_3 with the second lever L_2 .

According to one embodiment, an ideal braking ratio can first be evaluated/determined, and based on the same,

linkage between the automatic activation of the front/rear brakes can be performed to ensure that ideal or near ideal conditions are implemented when any of the two brakes are activated.

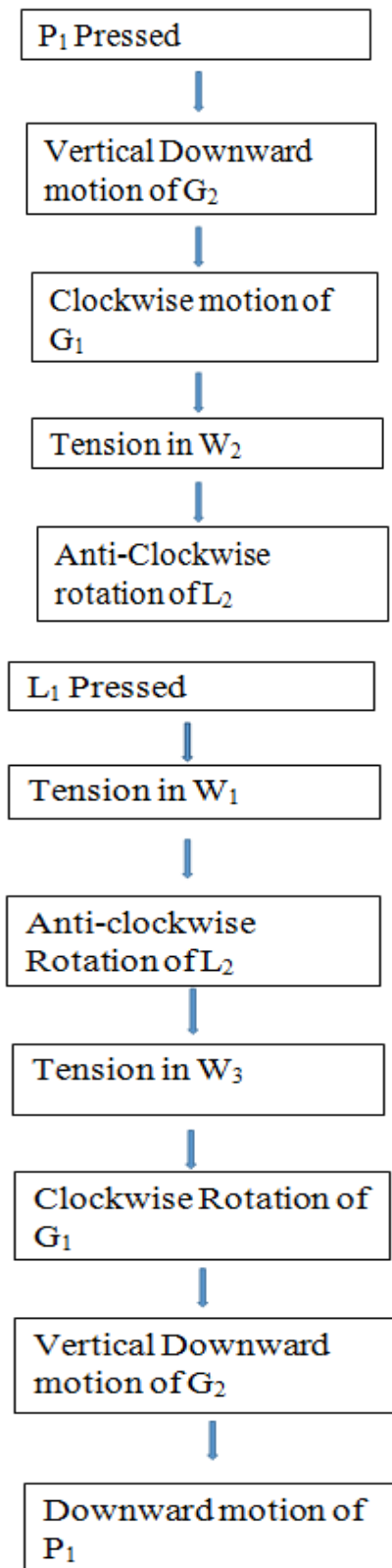

In case both the brakes are activated, the balance required to achieve the ideal/near-ideal braking ratio can be determined and accordingly either or both the brakes can be actuated to ensure optimal and safe braking.

According to one embodiment, the proposed linkage can be achieved by use of mechanical components including but not limited to gears and/or wires, and no external energy input is required to achieve the linkage between the two brakes.

According to another embodiment, when a vehicle equipped with the invention herein is ridden, if any one of the brake wires/cables (W_1 or W_2 or W_3) become severed, the cable remaining intact can still be capable of actuating either the front wheel brake or the rear wheel brake to ensure riding safety.

V. CONCLUSION

The present disclosure provides compensation for human errors in applying brakes.

The present disclosure provides a braking system that enables a linkage between the front and the rear brakes such that by pressing either of the front/rear brake, the other brake will automatically be applied in ideal proportion.

The present disclosure provides a braking system that can be installed in motorcycles without removing any component of existing brakes.

The present disclosure provides a braking system that uses simple mechanical components (such as gears, friction wheels and/or wires) to achieve the linkage between the two brakes.

The present disclosure provides a braking system that requires no external energy input to achieve the linkage between the two brakes.

The present disclosure provides a braking system that works in a manner such that when a vehicle is ridden, if any one of the brake wires/cables (W_1 or W_2 or W_3) become severed, the cable remaining intact can still be capable of actuating either the front wheel brake or the rear wheel brake to ensure riding safety.

The present disclosure provides a braking mechanism that can be fabricated at a very affordable cost.

REFERENCES

- [1] Hoffman, O., Eckert, A., Woywod, J. "The Motorcycle Integral Brakesystem MIB: an advanced brake solution for high performance motorcycles", 6. Internationale Motorradkonferenz, Köln, 9.-10.10.2006
- [2] Combined Brake and Steering Actuator for Automatic Vehicle Research R. Prohaska and P.

Devlin University of California PATH, 1357 S. 46th St. Richmond CA 94804